

ICC-ES Evaluation Report

ESR-2427

Reissued June 1, 2009

This report is subject to re-examination in one year.

www.icc-es.org | (800) 423-6587 | (562) 699-0543

A Subsidiary of the International Code Council®

DIVISION: 03—CONCRETE
Section: 03151—Concrete Anchoring
REPORT HOLDER:
ITW RED HEAD

2171 EXECUTIVE DRIVE, SUITE 100

ADDISON, ILLINOIS 60101

(800) 899-7890

www.itw-redhead.com
techsupport@itw-redhead.com
ADDITIONAL LISTEES:
ITW BRANDS

955 NATIONAL PARKWAY, SUITE 95500

SCHAUMBURG, ILLINOIS 60173

(877) 489-2726

www.itwbrands.com
ITW BUILDEX

1349 WEST BRYN MAWR AVENUE

ITASCA, ILLINOIS 60143

(800) BUILDEX

www.itwbuildex.com
EVALUATION SUBJECT
**ITW RED HEAD TRUBOLT + WEDGE ANCHORS FOR
CRACKED AND UNCRACKED CONCRETE**
1.0 EVALUATION SCOPE
Compliance with the following codes:

- 2006 *International Building Code*® (2006 IBC)
- 2006 *International Residential Code*® (2006 IRC)
- 2003 *International Building Code*® (2003 IBC)
- 2003 *International Residential Code*® (2003 IRC)
- 1997 *Uniform Building Code*™ (UBC)

Property evaluated:

Structural

2.0 USES

The RED HEAD Trubolt + Wedge Anchors are used to resist static, wind, and seismic tension and shear loads in cracked and uncracked normal-weight and structural sand-lightweight concrete having a specified compressive strength, f'_c , ranging from 2,500 psi to 8,500 psi (17.2 MPa

to 58.6 MPa). The 1/2-inch-diameter (12.7 mm) RED HEAD Trubolt + Wedge Anchor is also used to resist static, wind, and seismic tension and shear loads in cracked and uncracked normal-weight or structural sand-lightweight concrete over profile steel deck having a minimum specified compressive strength, f'_c , of 3,000 psi (20.7 MPa).

The anchors are alternatives to anchors described in Sections 1911 and 1912 of the 2006 IBC, Sections 1912 and 1913 of the 2003 IBC and Sections 1923.1 and 1923.2 of the UBC. The anchors may also be used where an engineered design is submitted in accordance with Section R301.1.3 of the 2006 IRC and the 2003 IRC.

3.0 DESCRIPTION
3.1 RED HEAD Trubolt + Wedge Anchor:

The RED HEAD Trubolt + Wedge Anchor is a torque-controlled, wedge-type mechanical expansion anchor, available in 1/2-inch (12.7 mm) and 5/8-inch (15.9 mm) diameters. The Trubolt + Wedge Anchor consists of a high-strength threaded stud, expansion clip, nut and washer. The anchor stud is cold-formed from low carbon steel materials with mechanical properties (yield and ultimate strengths) as described in Table 3 of this report. The zinc plating on the stud complies with ASTM B 633 SC1, Type III, with a minimum 0.0002-inch (5 µm) thickness. The expansion clip is fabricated from low carbon steel materials. The standard hexagonal steel nut conforms to ANSI B18.2.2-65 and the washer conforms to ANSI/ASME B18.22.1 1965 (R1981). The anchor stud consists of a threaded section throughout the majority of its length and a wedge section at the far end. The expansion clip is formed around the anchor, just above the wedge. The expansion clip consists of a split cylindrical ring with undercutting grooves at the bottom end. During torquing of the anchor, the grooves in the expansion clip are designed to cut into the walls of the concrete as the wedge portion of the stud is forced upward against the interior of the clip. The anchor is illustrated in Figure 1 of this report.

3.2 Concrete:

Normal-weight and structural sand-lightweight concrete must comply with Sections 1901.2, 1903 and 1905 of the IBC and UBC, as applicable.

3.3 Steel Deck Panels:

Steel deck panels must comply with ASTM A 653, SS Grade 40 (minimum), and must have a minimum 0.034-inch (0.864 mm) base-metal thickness (No. 20 gage).

4.0 DESIGN AND INSTALLATION

4.1 Strength Design:

4.1.1 General: Anchor design strengths must be determined in accordance with ACI 318-05 (ACI 318) Appendix D and this report. Design parameters are provided in Table 3 of this report. The anchor design must satisfy the requirements in ACI 318 D.4.1.1 and D.4.1.2. The values of f'_c used for calculation purposes must not exceed 8,000 psi (55.0 MPa). Strength reduction factors, ϕ , as given in ACI 318 D.4.4, must be used for load combinations calculated in accordance with Section 1605.2.1 of the IBC, Section 9.2 of ACI 318, or Section 1612.2.1 of the UBC. Strength reduction factors, ϕ , as given in ACI 318 D.4.5, must be used for load combinations calculated in accordance with ACI 318 Appendix C or Section 1909.2 of the UBC. Strength reduction factors, ϕ , corresponding to ductile steel elements may be used.

4.1.2 Requirements for Static Steel Strength in Tension, N_{sa} : The nominal static steel strength of a single anchor in tension, N_{sa} , calculated in accordance with ACI 318, Section D.5.1.2, is given in Table 3 of this report.

4.1.3 Requirements for Static Concrete Breakout Strength in Tension, N_{cb} , N_{cbg} : The nominal concrete breakout strength of a single anchor or a group of anchors in tension, N_{cb} or N_{cbg} respectively, must be calculated in accordance with ACI 318 D.5.2, with modifications as described in this section. The basic concrete breakout strength of a single anchor in tension, N_b , must be calculated in accordance with ACI 318 D.5.2.2, using the values of h_{ef} and k_{cr} as given in Table 3 of this report. The nominal concrete breakout strength in tension in regions where analysis indicates no cracking in accordance with ACI 318 D.5.2.6 must be calculated with $\psi_{c,N} = 1.0$ and using the value of k_{uncr} as given in Table 3 of this report.

For anchors installed in the soffit of structural sand-lightweight or normal-weight concrete-filled steel deck floor and roof assemblies, as shown in Figure 4, calculation of the concrete breakout strength in accordance with ACI 318 D.5.2 is not required. Section 4.1.4 of this report provides additional requirements concerning pullout strength in tension.

4.1.4 Requirements for Static Pullout Strength in Tension, N_{pn} : The nominal pullout strength of a single anchor in tension in accordance with ACI 318 D.5.3 in cracked and uncracked concrete, $N_{p,cr}$ or $N_{p,uncr}$, respectively, is given in Table 3 of this report. For all design cases, $\psi_{c,P} = 1.0$. In accordance with ACI 318 D.5.3.2, the nominal pullout strength in tension must be calculated according to Eq-1.

$$N_{pn,f'c} = N_{p,cr} \sqrt{\frac{f'_c}{2,500}} \quad (\text{lb, psi}) \quad (\text{Eq-1})$$

$$N_{pn,f'c} = N_{p,cr} \sqrt{\frac{f'_c}{17.2}} \quad (\text{N, MPa})$$

In regions where analysis indicates no cracking in accordance with ACI 318 D.5.3.6, the nominal pullout strength in tension must be calculated according to Eq-2:

$$N_{pn,f'c} = N_{p,uncr} \sqrt{\frac{f'_c}{2,500}} \quad (\text{lb, psi}) \quad (\text{Eq-2})$$

$$N_{pn,f'c} = N_{p,uncr} \sqrt{\frac{f'_c}{17.2}} \quad (\text{N, MPa})$$

Where values for $N_{p,cr}$ or $N_{p,uncr}$ are not provided in Table 3 of this report, the pullout strength in tension need not be evaluated.

The pullout strength in tension of the anchors installed in the soffit of structural sand lightweight or normal-weight concrete on steel deck floor and roof assemblies, as shown in Figure 4 of this report, is given in Table 6. In accordance with ACI 318 D.5.3.2, the nominal pullout strength in cracked concrete must be calculated according to Eq-1, whereby the value of $N_{p,deck,cr}$ must be substituted for $N_{p,cr}$ and the value 3,000 psi or 20.7 MPa must be substituted for 2,500 psi or 17.2 MPa. In regions where analysis indicates no cracking in accordance with ACI 318 D.5.3.6, the nominal pullout strength in tension must be calculated according to Eq-2, whereby the value of $N_{p,deck,uncr}$ must be substituted for $N_{p,uncr}$ and the value 3,000 psi or 20.7 MPa must be substituted for 2,500 psi or 17.2 MPa.

4.1.5 Requirements for Static Steel in Shear, V_{sa} : The values of V_{sa} for a single anchor given in Table 3 of this report must be used in lieu of the values of V_{sa} derived by calculation according to ACI 318 D.6.1.2.

The shear strength, $V_{s,deck}$, of anchors installed in the soffit of structural sand lightweight or normal-weight concrete on steel deck floor and roof assemblies, as shown in Figure 4 of this report, is given in Table 6 of this report.

4.1.6 Requirements for Static Concrete Breakout Strength in Shear, V_{cb} or V_{cbg} : The nominal static concrete breakout strength in shear of a single anchor or a group of anchors, V_{cb} or V_{cbg} , must be calculated in accordance with ACI 318 D.6.2. The basic concrete breakout strength in shear of a single anchor in cracked concrete, V_b , must be calculated in accordance with ACI 318 D.6.2.2 using the value of d_o given in Table 2 of this report, and the value l_e must be taken no greater than h_{ef} . In no cases must l_e exceed $8d_o$.

For anchors installed in the soffit of structural sand-lightweight or normal-weight concrete on steel deck floor and roof assemblies, as shown in Figure 4, calculation of the concrete breakout strength in accordance with ACI 318 D.6.2 is not required.

4.1.7 Requirements for Static Concrete Pryout Strength of Anchor in Shear, V_{cp} or V_{cpg} : The nominal concrete pryout strength shear of a single anchor or groups of anchors, V_{cp} or V_{cpg} , must be calculated in accordance with ACI 318 D.6.3, modified by using the value of k_{cp} provided in Table 3 of this report and the value of N_{cb} or N_{cbg} as calculated in Section 4.1.3 of this report.

For anchors installed in the soffit of structural sand-lightweight or normal-weight concrete on steel deck floor and roof assemblies, as shown in Figure 4 of this report, calculation of the concrete pryout strength in accordance with ACI 318 D.6.3 is not required.

4.1.8 Requirements for Minimum Member Thickness, Minimum Anchor Spacing and Minimum Edge Distance: Values of c_{min} and s_{min} as given in Table 3 of this report must be used in lieu of ACI 318 D.8.3. Minimum member thicknesses, h_{min} , as given in Table 3 of this report, must be used in lieu of ACI 318 D.8.5.

For anchors installed in the soffit of sand-lightweight or normal-weight concrete on steel deck floor and roof

assemblies, the anchors must be installed in accordance with Figure 4 of this report and the minimum anchor spacing along the flute must be the greater of $3h_{ef}$ or 1.5 times the flute width.

4.1.9 Requirements for Critical Edge Distance and Splitting: In applications where $c < c_{ac}$ and supplemental reinforcement to control splitting of the concrete is not present, the concrete breakout strength in tension for uncracked concrete, calculated according to ACI 318 D.5.2, must be further multiplied by the factor $\Psi_{cp,N}$ given by Eq-3:

$$\Psi_{cp,N} = c / c_{ac} \tag{Eq-3}$$

whereby the factor $\Psi_{cp,N}$ need not be taken as less than $1.5h_{ef} / c_{ac}$. For all other cases $\Psi_{cp,N} = 1.0$. Values for the critical edge distance c_{ac} must be taken from Table 3 of this report.

4.1.10 Requirements for Seismic Design:

4.1.10.1 General: For load combinations including earthquake, the design must be performed according to ACI 318 D.3.3 as modified by Section 1908.1.16 of the 2006 IBC, as follows:

CODE	ACI 318 D.3.3 SEISMIC REGION	EQUIVALENT CODE DESIGNATION
2003 IBC and 2003 IRC	Moderate or high seismic risk	Seismic Design Categories C, D, E, and F
UBC	Moderate or high seismic risk	Seismic Zones 2B, 3 and 4

The nominal steel strength and the nominal concrete breakout strength for anchors in tension, and the nominal concrete breakout strength and pryout strength for anchors in shear, must be calculated according to ACI 318 D.5 and D.6, respectively, taking into account the corresponding values given in Table 3 of this report.

The anchors comply with ACI 318 D.1 as ductile steel elements and must be designed in accordance with ACI 318 D.3.3.4 or D.3.3.5.

4.1.10.2 Seismic Tension: The nominal steel strength and nominal concrete breakout strength for anchors in tension must be calculated according to ACI 318 D.5.1 and D.5.2, as described in Sections 4.1.2 and 4.1.3 of this report and in accordance with ACI 318 D.5.3.2. The value for nominal pullout strength tension for seismic loads, N_{eq} or $N_{p,deck,cr}$, given in Table 3 or 6 of this report, must be used in lieu of N_{pn} . The values of N_{eq} must be adjusted for the concrete strength in accordance with Eq-4:

$$N_{eq,f'c} = N_{eq} \sqrt{\frac{f'_c}{2,500}} \quad (\text{lb, psi}) \tag{Eq-4}$$

$$N_{eq,f'c} = N_{eq} \sqrt{\frac{f'_c}{17.2}} \quad (\text{N, MPa})$$

If no values for N_{eq} are given in Table 3, the static design strength values govern. Section 4.1.4 provides additional requirements.

4.1.10.3 Seismic Shear: The nominal concrete breakout strength and pryout strength for anchors in shear must be calculated according to ACI 318 D.6.2 and D.6.3, as described in Sections 4.1.6 and 4.1.7 of this report and in accordance with ACI 318 D.6.1.2. The value for nominal steel strength in shear for seismic loads, V_{eq} or $V_{sa,deck}$, given in Table 3 or 6 of this report, must be used in lieu of V_{sa} .

4.1.11 Interaction of Tensile and Shear Forces: For designs that include combined tension and shear, the interaction of tension and shear loads must be calculated in accordance with ACI 318 D.7.

4.1.12 Requirements for Structural Sand Lightweight Concrete: Where installation in structural sand-lightweight concrete is intended, the N_b , N_{pn} , N_{eq} , $N_{p,uncr}$, $N_{p,cr}$, V_b , V_{cp} , V_{cpq} and V_{eq} values must be multiplied by 0.60, in lieu of ACI 318 D.3.4. For anchors installed in the soffit of structural sand-lightweight concrete-filled steel deck floor and roof assemblies, this reduction is not required.

4.2 Allowable Stress Design (ASD):

4.2.1 General: For anchors designed using load combinations in accordance with IBC Section 1605.3 or UBC Section 1612.3, allowable loads must be established using Eq-5 and Eq-6:

$$T_{allowable,ASD} = \phi N_n / \alpha \tag{Eq-5}$$

and

$$V_{allowable,ASD} = \phi V_n / \alpha \tag{Eq-6}$$

where

$T_{allowable,ASD}$ = Allowable tension load (lbf or kN).

$V_{allowable,ASD}$ = Allowable shear load (lbf or kN).

ϕN_n = Lowest design strength of an anchor or anchor group in tension as determined in accordance with ACI 318 Appendix D with amendments in Section 4.1 of this report and Section 1908.1.16 of the 2006 IBC, as applicable.

ϕV_n = Lowest design strength of an anchor or anchor group in shear as determined in accordance with ACI 318 Appendix D with amendments in Section 4.1 of this report and Section 1908.1.16 of the 2006 IBC, as applicable.

α = Conversion factor calculated as a weighted average of the load factors for the controlling load combination. In addition, α must include all applicable factors to account for nonductile failure modes and required over-strength.

An example of allowable stress design values for illustrative purposes is shown in Table 4 of this report.

4.2.2 Interaction of Tensile and Shear Forces: In lieu of ACI 318 D.7.1, D.7.2 and D.7.3, interaction must be calculated as follows:

For shear loads $V \leq 0.2 \cdot V_{allow, ASD}$, the full allowable load in tension, $T_{allow, ASD}$, may be taken.

For tension loads $T \leq 0.2 \cdot T_{allow, ASD}$, the full allowable load in shear, $V_{allow, ASD}$, may be taken.

For all other cases, Eq-7 applies:

$$T/T_{allow, ASD} + V/V_{allow, ASD} \leq 1.2 \tag{Eq-7}$$

4.3 Installation:

Installation parameters are provided in Tables 2 and 5 and Figures 3 and 4. Anchor locations must comply with this report and the plans and specifications approved by the code official. The RED HEAD Trubolt + Wedge Anchors must be installed according to ITW's published instructions and this report. Holes must be predrilled in concrete with a compressive strength from 2,500 to 8,500 psi (17.2 to 58.6

MPa) at time of installation, using carbide-tipped masonry drill bits manufactured within the range of the maximum and minimum drill tip dimensions of ANSI Standard B212.15-1994. The nominal drill bit diameter must be equal to that of the anchor. The minimum drilled hole depth, h_o , must comply with Table 2 of this report. Embedment, spacing, edge distance, and minimum concrete thickness must comply with Table 3. The predrilled holes must be cleaned to remove loose particles, using pressurized air. The nut and washer must be assembled on the end of the anchor, leaving the nut flush with the end of the anchor. The anchors must be driven through the fixture and must then be hammered into the predrilled hole to the required embedment depth in concrete. The nut must be tightened against the washer until the specified torque values listed in Table 2 are achieved.

For installation in the soffit of sand-lightweight or normal-weight concrete on steel deck floor and roof assemblies, the hole diameter in the steel deck must not exceed the diameter of the hole in the concrete by more than $1/8$ inch (3.2 mm). For member thickness, edge distance, spacing restrictions, and installations torque values for installation into the soffit of sand-lightweight or normal-weight concrete on steel deck floor and roof assemblies, see Figure 4, Table 5, and Section 4.1.8 of this report.

4.4 Special Inspection:

Special inspection is required in accordance with Section 1704.13 of the IBC and Section 1701.5.2 of the UBC. The special inspector must make periodic inspections during anchor installation to verify anchor type, anchor dimensions, concrete type, concrete compressive strength, drill bit type, hole dimensions, hole cleaning procedures, edge distance, anchor spacing, concrete member thickness, anchor embedment, tightening torque, and adherence to the manufacturer's published installation instructions. The special inspector must be present as often as required in accordance with the statement of special inspection. Under the IBC, additional requirements as set forth in Sections 1705 and 1706 must be observed, where applicable.

5.0 CONDITIONS OF USE

The RED HEAD Trubolt + Wedge Anchors described in this report comply with, or are suitable alternatives to what is specified in, those codes listed in Section 1.0 of this report, subject to the following conditions.

- 5.1 The anchors must be installed in accordance with ITW's published instructions and this report. In case of conflicts, this report governs.
- 5.2 Anchor sizes, dimensions, and installation parameters are as set forth in this report.
- 5.3 The anchors are limited to installation in cracked and uncracked, normal-weight or structural sand-lightweight concrete having a specified compressive strength, f'_c , of 2,500 psi to 8,500 psi (17.2 MPa to 58.6 MPa). The $1/2$ -inch-diameter (12.7 mm) anchors may also be installed in cracked and uncracked normal-weight or structural sand-lightweight concrete over profile steel deck having a minimum specified compressive strength, f'_c , of 3,000 psi (20.7 MPa).
- 5.4 The values of f'_c used for calculation purposes must not exceed 8,000 psi (55.0 MPa).
- 5.5 Strength design values must be established in accordance with Section 4.1 of this report.
- 5.6 Allowable design values must be established in accordance with Section 4.2.
- 5.7 Anchor spacing, edge distance, and minimum member thickness must comply with Table 3 of this report.
- 5.8 Prior to installation, calculations and details justifying that the applied loads comply with this report must be submitted to the code official for approval. The calculations and details must be prepared by a registered design professional where required by the statutes of the jurisdiction in which the project is to be constructed.
- 5.9 Since an ICC-ES acceptance criteria for evaluating data to determine the performance of expansion anchors subjected to fatigue or shock loading is unavailable at this time, the use of these anchors under such conditions is beyond the scope of this report.
- 5.10 Anchors may be installed in regions of concrete where cracking has occurred or where analysis indicates cracking may occur ($f_t > f_t$), subject to the conditions of this report.
- 5.11 Anchors may be used to resist short-term loading due to wind or seismic forces, subject to the conditions of this report.
- 5.12 Where not otherwise prohibited in the code, RED HEAD Trubolt + Wedge Anchors are permitted for use with fire-resistance-rated construction provided that at least one of the following conditions is fulfilled:
 - Anchors are used to resist wind or seismic forces only.
 - Anchors that support a fire-resistance-rated envelope or a fire-resistance-rated membrane are protected by approved fire-resistance-rated materials, or have been evaluated for resistance to fire exposure in accordance with recognized standards.
 - Anchors are used to support nonstructural elements.
- 5.13 Use of the anchors is limited to dry, interior locations.
- 5.14 Special inspections are provided in accordance with Section 4.4 of this report.
- 5.15 The anchors are manufactured at Hanover Park, Illinois; Iron Ridge, Wisconsin; Watertown, Wisconsin; Itasca, Illinois; and Michigan City, Indiana; under a quality control program with inspections by PFS Corporation (AA-652).

6.0 EVIDENCE SUBMITTED

Data complying with the ICC-ES Acceptance Criteria for Mechanical Anchors in Concrete Elements (AC193), dated February 2009, for use in cracked and uncracked concrete, including optional tests for seismic tension and shear; profile steel deck soffit tests; and quality control documentation.

7.0 IDENTIFICATION

The anchors are identified by their dimensional characteristics and the anchor size, and by a length identification marking stamped on the anchor, as indicated in Table 1 of this report. The anchors have the length identification marking underlined on the anchor head, as illustrated in Figure 2, and this is visible after installation for verification. Packages are identified with the anchor name, type and size; the manufacturer's name (ITW Red Head, ITW Brands, or ITW Buildex) and address; the evaluation report number (ICC-ES ESR-2427); and the name of the inspection agency (PFS Corporation).

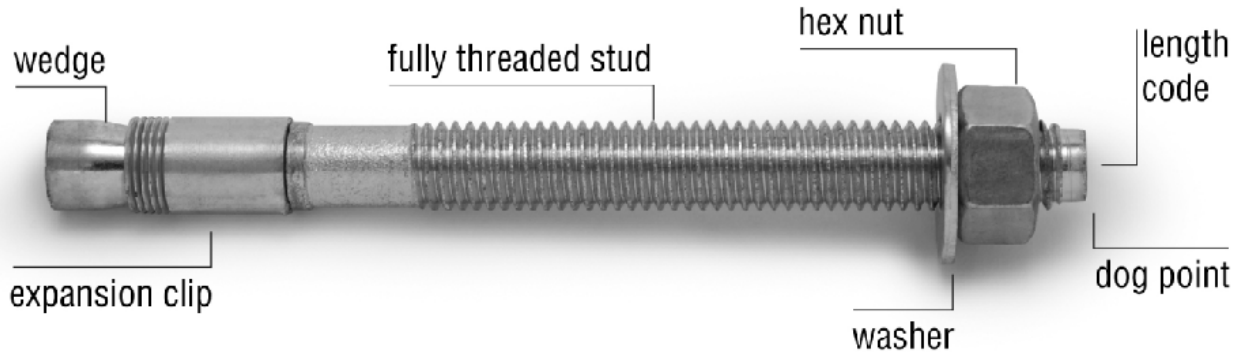

FIGURE 1—ITW RED HEAD TRUBOLT + WEDGE ANCHOR

TABLE 1—LENGTH IDENTIFICATION MARKINGS¹

LENGTH (inches)	ID MARKING ON ANCHOR HEAD												
	C	D	E	F	G	H	I	J	K	L	M	N	O
From	2 ¹ / ₂	3	3 ¹ / ₂	4	4 ¹ / ₂	5	5 ¹ / ₂	6	6 ¹ / ₂	7	7 ¹ / ₂	8	8 ¹ / ₂
Up to, but not including	3	3 ¹ / ₂	4	4 ¹ / ₂	5	5 ¹ / ₂	6	6 ¹ / ₂	7	7 ¹ / ₂	8	8 ¹ / ₂	9

For SI: 1 inch = 25.4 mm.

¹Figure 2 shows a typical marking.



FIGURE 2—ITW RED HEAD TRUBOLT + WEDGE ANCHOR LENGTH IDENTIFICATION MARKING

TABLE 2—ITW RED HEAD TRUBOLT+ WEDGE ANCHOR INSTALLATION INFORMATION

PARAMETER	NOTATION	UNITS	NOMINAL ANCHOR DIAMETER (inch)			
			$\frac{1}{2}$		$\frac{5}{8}$	
Anchor outer diameter	d_o	inches	0.5		0.615	
Nominal carbide bit diameter	d_{bit}	inches	$\frac{1}{2}$		$\frac{5}{8}$	
Effective embedment depth	h_{ef}	inches	2	$3\frac{1}{4}$	$2\frac{3}{4}$	$4\frac{1}{4}$
Minimum anchor embedment depth	h_{nom}	inches	$2\frac{1}{2}$	$3\frac{3}{4}$	$3\frac{1}{4}$	$4\frac{3}{4}$
Minimum hole depth ¹	h_o	inches	$2\frac{3}{4}$	4	$3\frac{1}{2}$	5
Minimum concrete member thickness ¹	h_{min}	inches	4	6	6	8
Minimum overall anchor length	l	inches	$3\frac{3}{4}$	$4\frac{1}{2}$	$4\frac{1}{4}$	6
Installation torque	T_{inst}	ft-lb	45		90	
Minimum diameter of hole in fastened part	d_h	inches	$\frac{9}{16}$		$\frac{11}{16}$	

For SI: 1 inch = 25.4 mm, 1 ft-lb = 1.356 N-m.

¹For installation in the soffit of concrete on steel deck floor or roof assemblies, see Figure 4. Anchors in the lower and in the upper flute may be installed with a maximum 1-inch offset in either direction from the center of the flute. In addition, anchors must have an axial spacing along the flute equal to the greater of $3h_{ef}$ or 1.5 times the flute width.

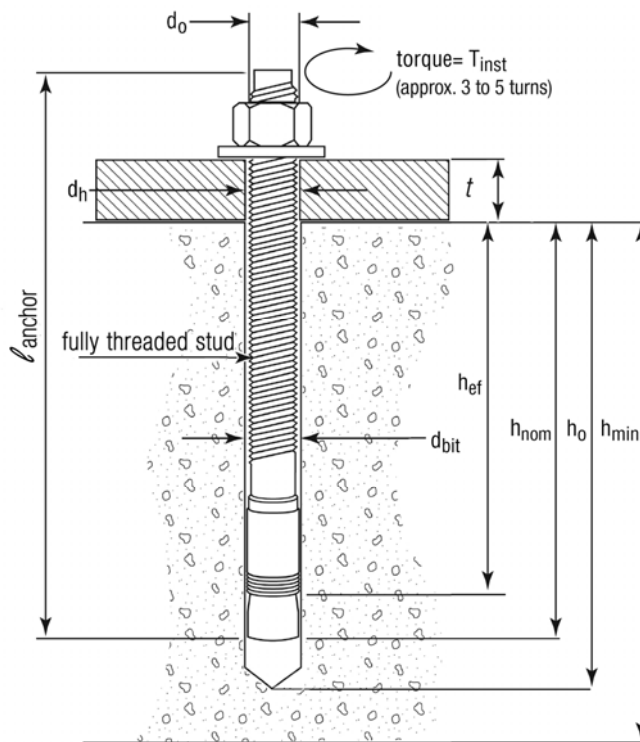

FIGURE 3—ITW RED HEAD TRUBOLT + WEDGE ANCHOR (INSTALLED)

TABLE 3—ITW RED HEAD TRUBOLT + WEDGE ANCHOR DESIGN INFORMATION¹

CHARACTERISTIC	SYMBOL ⁵	UNITS	NOMINAL ANCHOR DIAMETER (inch)						
			¹ / ₂		³ / ₄		⁵ / ₈ ⁴		
Installation Instructions									
Minimum effective embedment depth	h_{ef}	In.	2		3 ¹ / ₄		2 ³ / ₄		4 ¹ / ₄
Minimum concrete member thickness	h_{min}	In.	4	6	6	8	6	8	
Critical edge distance	c_{ac}	In.	6	6	7 ¹ / ₂	6	7 ¹ / ₂	7 ¹ / ₂	
Minimum edge distance	c_{min}	In.	6	6	6	6	7 ¹ / ₂	5	
Minimum anchor spacing	s_{min}	In.	6	5 ³ / ₄	4	5 ³ / ₄	8	6	
Anchor Data									
Anchor category	1, 2 or 3	—	1						
Minimum specified yield strength	f_y	psi	55,000						
Minimum specified ultimate strength	f_{uta} (f_{ut})	psi	75,000						
Effective tensile stress area (neck)	A_{se}	in ²	0.119			0.183			
Steel strength in tension	N_{sa} (N_s)	lbf	8,925			13,725			
Effective tensile stress area (thread)	A_{se}	in ²	0.142			0.217			
Steel strength in shear ⁶	V_{sa} (V_s)	lbf	5,175			8,955			
Effectiveness factor for uncracked concrete	k_{uncr}	—	24						
Effectiveness factor for cracked concrete	k_{cr}	—	17						
Modification factor for cracked and uncracked concrete ³	$\Psi_{c,N}$ (Ψ_3)	—	1.0						
Pullout strength, uncracked concrete	$N_{p,uncr}$	lbf	-	6,540		5,430		8,900	
Pullout strength, cracked concrete	$N_{p,cr}$	lbf	-	-		-		-	
Tension pullout strength for seismic loads	N_{eq}	lbf	-	-		-		6,715	
Steel strength in shear for seismic loads	V_{eq} ($V_{sa, seis}$)	lbf	5,175			8,955			
Load-bearing length of anchor	$l_e(l)$	in	2	3 ¼		2 ¾		4 ¼	
Axial stiffness in service load range in uncracked concrete	β_{uncr}	lbf /in	250,000						
Axial stiffness in service load range in cracked concrete	β_{cr}	lbf /in	20,000						
Coefficient for pryout strength	k_{cp}	—	1.0		2.0				
Strength reduction factor ϕ for tension, steel failure modes ²			0.75						
Strength reduction factor ϕ for shear, steel failure modes ²			0.65						
Strength reduction factor ϕ for tension, concrete failure modes, Condition B ²			0.65						
Strength reduction factor ϕ for shear, concrete failure modes, Condition B ²			0.70						

For **SI**: 1 inch = 25.4 mm, 1 in² = 645.16 mm², 1 lbf = 4.45 N, 1 psi = 0.006895 MPa, 1 lbf 10²/in = 17,500 N/m.

¹The Trubolt + Wedge Anchor is a ductile steel element as defined by ACI 318 D.1.

²All values of ϕ apply to the load combinations of IBC Section 1605.2, ACI 318 Section 9.2 or UBC Section 1612.2. If the load combinations of Appendix C or UBC Section 1909.2 are used, the appropriate value of ϕ must be determined in accordance with ACI 318 D.4.5. For installations where reinforcement that complies with ACI 318 Appendix D requirements for Condition A is present, the appropriate ϕ factor must be determined in accordance with ACI 318 D.4.4.

³For all design cases $\Psi_{c,N} = 1.0$. The appropriate effectiveness factor for cracked concrete (k_{cr}) or uncracked concrete (k_{uncr}) must be used.

⁴The actual diameter for the ⁵/₈-inch-diameter anchor is 0.615 inch.

⁵The notations in brackets are for the 2003 IBC.

⁶Steel strength in shear values are based on test results in accordance with ACI 355.2, Section 9.4, and must be used for design.

TABLE 4—EXAMPLE OF ITW RED HEAD TRUBOLT+ WEDGE ANCHOR ALLOWABLE STRESS DESIGN (ASD) VALUES, FOR ILLUSTRATIVE PURPOSES

ANCHOR NOTATION	ANCHOR EMBEDMENT DEPTH, h_{nom} , (inches)	EFFECTIVE EMBEDMENT DEPTH, h_{ef} , (inches)	ALLOWABLE TENSION LOAD (lbs)
1/2	2 1/2	2	1,490
	3 3/4	3 1/4	2,870
5/8	3 1/4	2 3/4	2,385
	4 3/4	4 1/4	3,910

For SI: 1 inch = 25.4 mm, 1 lbf = 4.45 N.

Design assumptions:

- ¹Single anchor with static tension load only.
- ²Concrete determined to remain uncracked for the life of the anchorage.
- ³Load combinations from ACI 318 Section 9.2 (no seismic loading).
- ⁴Thirty percent dead load and 70 percent live load, controlling load combination 1.2D + 1.6L.
- ⁵Calculation of weighted average for α : 1.2D + 1.6L = 1.2(0.3) + 1.6(0.7) = 1.48.
- ⁶ $f_c = 2,500$ psi (normal-weight concrete).
- ⁷ $C_{a1} = C_{a2} > C_{ac}$.
- ⁸ $h \geq h_{min}$.

Illustrative Procedure to Calculate Allowable Stress Design Tension Value:

RED HEAD Trubolt+ Wedge Anchor, 1/2-inch-diameter, using an effective embedment of 3 1/4 inches, and assuming the conditions given in Table 4.

PROCEDURE		CALCULATION	
Step 1	Calculate steel strength of a single anchor in tension per ACI 318 D 5.1.2, Table 3 of this report	ϕN_{sa}	$= \phi N_{sa}$ $= 0.75 * 8,925$ = 6,694 lbs steel strength
Step 2	Calculate concrete breakout strength of a single anchor in tension per ACI 318 D 5.2.2, Table 3 of this report	N_b ϕN_{cb}	$= k_{uncr} \sqrt{f_c} h_{ef}^{1.5}$ $= 24 * \sqrt{2,500} * 3.25^{1.5}$ $= 7,031$ lbs $= \phi A_{NC} / A_{NC0} \psi_{ed,N} \psi_{c,N} \psi_{cp,N} N_b$ $= 0.65 * (95/95) / 1.0 * 1.0 * 1.0 * 7,031$ $= 0.65 * 7,031$ = 4,570 lbs concrete breakout strength
Step 3	Calculate pullout strength in tension per ACI 318 D 5.3.2 and Table 3 of this report	ϕN_{pn}	$= \phi N_{p,uncr} \psi_{c,P} (f_{c,act} / 2,500)^n$ $= 0.65 * 6,540 * 1.0 * 1.0^{0.5}$ = 4,251 lbs pullout strength
Step 4	Determine controlling resistance strength in tension per ACI 318 D 4.1.1 and D 4.1.2		= 4,251 lbs controlling resistance
Step 5	Calculate allowable stress design conversion factor for loading condition per ACI 318 Section 9.2:	α	$= 1.2D + 1.6L$ $= 1.2(0.3) + 1.6(0.7)$ = 1.48
Step 6	Calculate allowable stress design value per Section 4.2 of this report	$T_{allowable,ASD}$	$= \phi N_n / \alpha$ $= 4,251 / 1.48$ = 2,870 lbs allowable stress design

TABLE 5—ITW RED HEAD TRUBOLT+ WEDGE ANCHOR INSTALLATION INFORMATION FOR INSTALLATION IN THE SOFFIT OF CONCRETE FILL ON METAL DECK FLOOR AND ROOF ASSEMBLIES^{1,2}

PARAMETER	SYMBOL	UNITS	NOMINAL ANCHOR DIAMETER (inch)		
			1/2		
Anchor outer diameter	d_o	inches	0.5		
Nominal carbide bit diameter	d_{bit}	inches	1/2		
Location of installation			Upper flute only	Lower flute only	Lower flute only
Minimum effective embedment depth	h_{ef}	inches	1 3/4	2	3 1/4
Anchor embedment depth	h_{nom}	inches	2 1/4	2 1/2	3 3/4
Minimum hole depth	h_o	inches	2 1/2	2 3/4	4
Minimum overall anchor length	l	inches	3 3/4	3 3/4	4 1/2
Installation torque	T_{inst}	ft-lb	45		
Minimum diameter of hole in fastened part	d_h	inches	9/16		

For SI: 1 inch = 25.4 mm, 1 ft-lb = 1.356 N-m.

¹Anchors in the lower and upper flute may be installed with a maximum 1-inch offset in either direction from the center of the flute. In addition, anchors must have an axial spacing along the flute equal to the greater of $3h_{ef}$ or 1.5 times the flute width.

²Figure 4 provides additional installation information including concrete member thickness.

TABLE 6—ITW RED HEAD TRUBOLT+ WEDGE ANCHOR DESIGN INFORMATION FOR INSTALLATION IN THE SOFFIT OF CONCRETE FILL ON METAL DECK FLOOR AND ROOF ASSEMBLIES

CHARACTERISTIC	SYMBOL	UNITS	NOMINAL ANCHOR DIAMETER OF 1/2 INCH		
			Upper Flute	Lower Flute	
			$h_{ef} = 1 3/4$ inches	$h_{ef} = 2$ inches	$h_{ef} = 3 1/4$ inches
Characteristic pullout strength, uncracked concrete over metal deck	$N_{p, deck, uncr}$ ¹	lbf	2,515	2,515	5,285
Characteristic pullout strength, cracked concrete over metal deck	$N_{p, deck, cr}$ ¹	lbf	1,780	1,780	4,025
Reduction factor for pullout strength in tension, Condition B	ϕ^2	-	0.65		
Characteristic shear strength, concrete over metal deck	$V_{sa, deck}$	lbf	2,200	2,200	3,790
Reduction factor for steel strength in shear	ϕ^2	-	0.65		

For SI: 1 inch = 25.4 mm, 1 lbf = 4.45 N.

¹Values for $N_{p, deck}$ and $V_{sa, deck}$ apply to structural sand-lightweight concrete having a minimum concrete compressive strength, f'_c , of 3,000 psi.

²All values of ϕ apply to the load combinations of IBC Section 1605.2, ACI 318 Section 9.2 or UBC Section 1612.2. If the load combinations of Appendix C or UBC Section 1909.2 are used, the appropriate value of ϕ must be determined in accordance with ACI 318 D.4.5. For installations where reinforcement that complies with ACI 318 Appendix D requirements for Condition A is present, the appropriate ϕ factor must be determined in accordance with ACI 318 D.4.4.

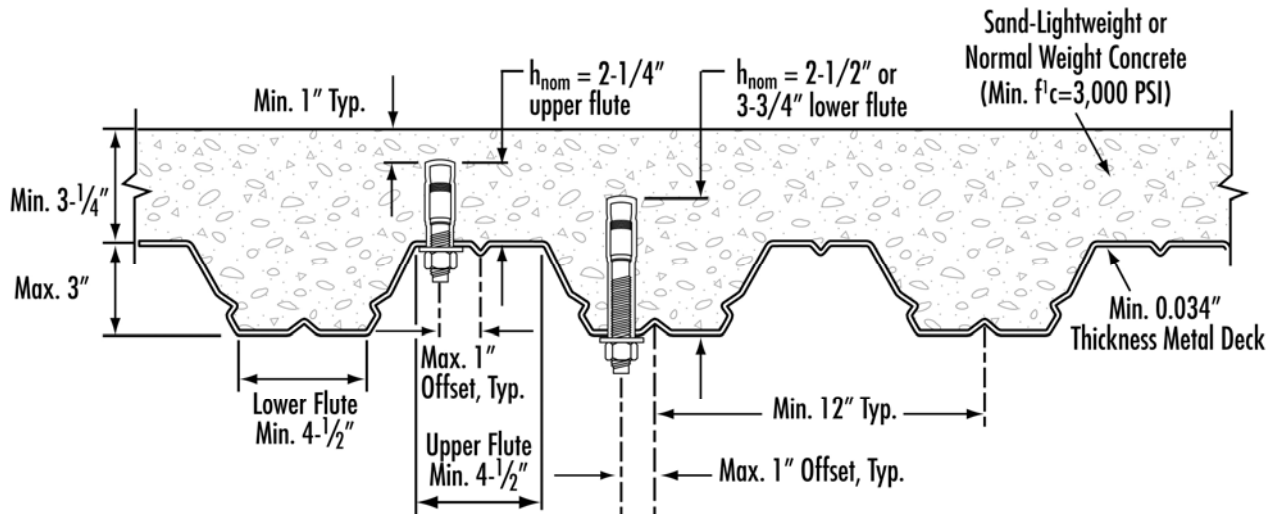

FIGURE 4—ITW RED HEAD TRUBOLT+ WEDGE ANCHOR INSTALLATION IN THE SOFFIT OF CONCRETE OVER STEEL DECK FLOOR AND ROOF ASSEMBLIES (1 inch = 25.4 mm)